

Please read through this user's manual to ensure correct usage of the controller and keep it handy for quick reference.

Contents

1. Notice	1
2. What is on the Front Panel?	1
3. Installing the Controller	1
4. Panel Cutout Dimensions and External Dimensions	1
5. Wiring	2
6. Hardware Specifications	2
7. Key Operations (Parameter Settings)	2
8. Limit Control Function	4
9. Troubleshooting	4

Revision Record

IM 05C01E22-01E 1st Edition:	Oct. '00
2nd Edition:	Feb. '01
3rd Edition:	Mar. '01
4th Edition:	Jun. '04
5th Edition:	Sep. '04
6th Edition:	Apr. '05

1. Notice

The following safety symbol is used both on the product and in this user's manual.



This symbol stands for "Handle with Care." When displayed on the product, the operator should refer to the corresponding explanation given in the user's manual in order to avoid injury or death of personnel and/or damage to the product. In the manual the symbol is accompanied by an explanation of the special care that is required to avoid shock or other dangers that may result in injury or loss of life.

The following symbols are used in this manual only.



NOTE

Indicates that operating the hardware or software in a particular manner may lead to damage or result in system failure.



IMPORTANT

Draws attention to information that is essential for understanding the operation and/or features of the product.

Exemption from Responsibility

Make sure that all of the precautions are strictly adhered to. Yokogawa Electric Corporation assumes no liability for any damage resulting from use of the instrument in contradiction to the precautions.

Also, Yokogawa Electric Corporation assumes no liability to any party for any loss or damage, direct or indirect, caused by the use or any unpredictable defect of the instrument.

2. What is on the Front Panel ?

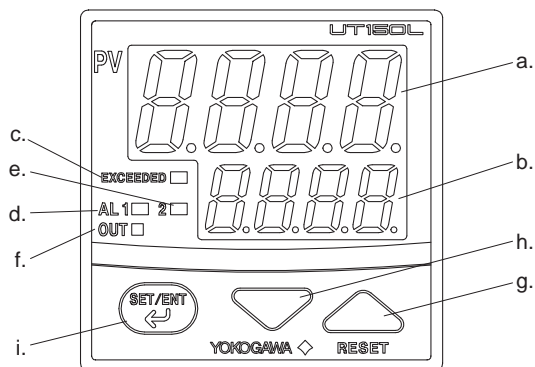

Name	Function
a. PV display (red)	Indicates PV (measured value) and character information such as parameter codes and error codes.
b. SP display (green)	Indicates SP (target setpoint) and parameter values.
c. EXCEEDED lamp (green)	Lit while PV is exceeding SP value.
d. Alarm 1 (AL1) lamp (red)	Lit when alarm 1 is activated.
e. Alarm 2 (AL2) lamp (red)	Lit when alarm 2 is activated.
f. Output (OUT) display lamp	<ul style="list-style-type: none"> Lit when PV exceeds SP value. This lamp does not go out until "confirming operation" is done (see Page 4). Note: Output relay contact is off when OUT lamp lights.
g. Reset/Data change (up) key	<ul style="list-style-type: none"> Pressing the key for 1 second or longer in "operating display ① or ②" puts out Output(OUT) display lamp. (This operation is the "confirming operation".) Pressing the key for 1 second or longer in "confirmation display" resets "exceeded status(PV exceeds SP value)", "duration time" or max./min. PV value those UT150L observed before. Pressing the key increases the data value. Holding down the key will gradually increase the speed of change.
h. Data change (down) key	<ul style="list-style-type: none"> Pressing the key decreases the data value. Holding down the key will gradually increase the speed of change.
i. SET/ENT key (data registering key) (Indicated as simply the key hereafter.)	<ul style="list-style-type: none"> Registers the data value changed using the data change keys. Switches between parameter setting displays sequentially. Pressing the key for 3 seconds or longer in the operating display retrieves the operating parameter setting display. Pressing the key for 3 seconds or longer in either an operating or setup parameter setting display transfers back to the operating display ①.

3. Installing the Controller

CAUTION

- To prevent electric shock, the source of power to the controller must be turned off when mounting the controller on to a panel.
- Since the controller is not of explosion-proof type, do not use this controller in combustible or explosive gas atmospheres.

NOTE

To install the controller, select a location where:

- No-one may accidentally touch the terminals;
- Mechanical vibrations are minimal;
- Corrosive gas is minimal;
- The temperature can be maintained at about 23°C with minimal fluctuation;
- There is no direct heat radiation;
- There are no resulting magnetic disturbances;
- The terminal board (reference junction compensation element, etc.) is protected from wind;
- There is no splashing of water; and
- There are no flammable materials.

Checking Package Contents

Before using the product, check that its model & suffix codes are as you ordered.

Model and Suffix Codes

Model	Suffix code	Description
UT150L		Limit Controller (1/16 DIN size)
Control output	-R	Relay output (time-proportional PID or on/off control)
	N	Always N
Option	/AL	Alarm outputs (2 points)
	/EX	Digital input (1 point)
	/RET	PV retransmission output in 4 to 20mA
	/RS	Communication function

Check the package contents against the list below.

- Limit controller 1
- Mounting bracket 1 for UT150L
- User's manual (IM 05C01E22-01E) 1

Yokogawa Electric Corporation

2-9-32, Naka-cho Musashino-shi, Tokyo 180-8750 Japan
Phone: +81-422-52-7179 Facsimile: +81-422-52-6793

Never place the controller directly on flammable items.

If the controller has to be installed close to flammable items or equipment, be sure to enclose the controller in shielding panels positioned at least 150mm away from each side. These panels should be made of either 1.43mm thick metal-plated steel plates or 1.6mm thick uncoated steel plates.

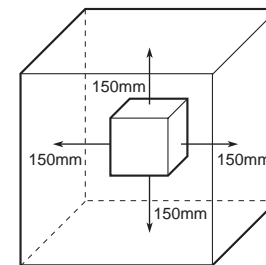

- Mount the controller at an angle within 30° from horizontal with the screen facing upward. Do not mount it facing downward.

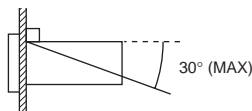

Mounting the Controller

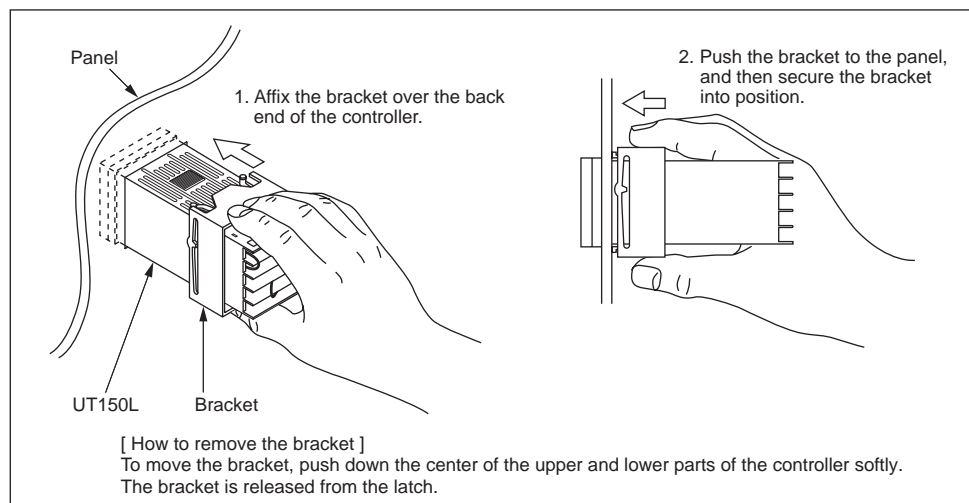

4. Panel Cutout Dimensions and External Dimensions

1. General Mounting

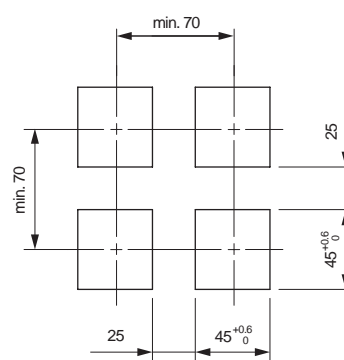

2. Side-by-side Close Mounting

(Splash-proof construction is unavailable)

Unit: mm

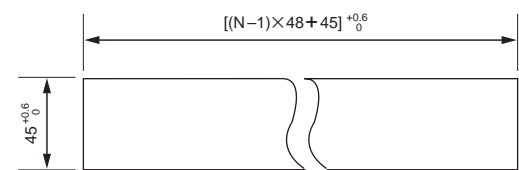

N is the number of controllers.
If N ≥ 5, then measure the actual length.

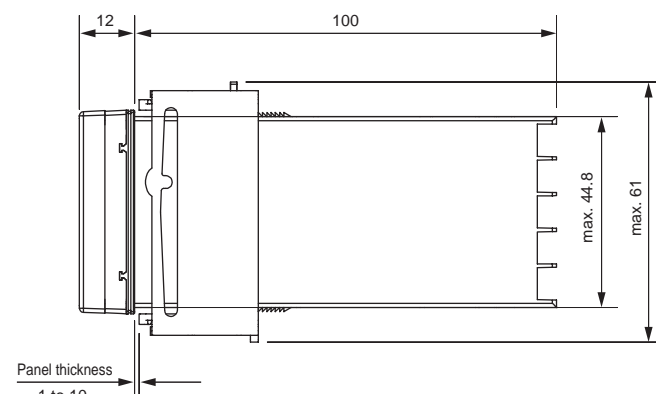
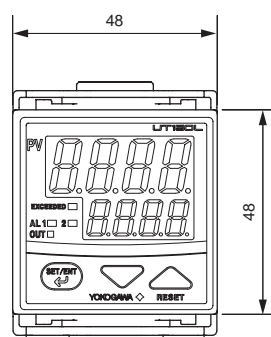
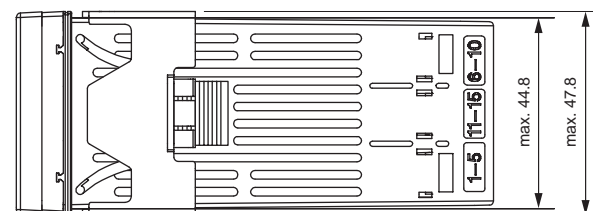

5. Wiring

CAUTION

- Before you start wiring, turn off the power source and use a tester to check that the controller and cables are not receiving any power in order to prevent electric shock.
- For safety, be sure to install a circuit breaker switch (of 5A and 100V AC or 220V AC, and that conforms to IEC60947) near the controller so as to be operated easily, and clearly indicate that the device is used to de-energize the controller.
- Wiring should be carried out by personnel with appropriate electrical knowledge and experience.

NOTE

- Use a single-phase power source. If the source has a lot of noise, use an isolation transformer for the primary side and a line filter (we recommend TDK's ZAC2205-00U product) for the secondary side. When this noise-prevention measure is taken, keep the primary and secondary power cables well apart. Since the controller has no fuse, be sure to install a circuit breaker switch (of 5A and 100V AC or 220V AC, and that conforms to IEC standards) and clearly indicate that the device is used to de-energize the controller.
- For thermocouple input, use shielded compensating lead wires. For RTD input, use shielded wires which have low resistance and no resistance difference between the 3 wires. See the table given later for the specifications of the cables and terminals and the recommended products.
- The control output relay cannot be replaced even though it has a limited service life (100,000 relay contacts for the resistance load). Thus, an auxiliary relay should be used so that the load can be turned on and off.
- When using an inductive load (L) such as an auxiliary relay and solenoid valve, be sure to insert a CR filter (for AC) or diode (for DC) in parallel as a spark-rejecting surge suppressor to prevent malfunctions or damage to the relay.
- When there is the possibility of being struck by external lightning surge, use the arrester to protect the instrument.

NOTE

Always fix a terminal cover bracket to the UT150L limit controller before wiring if an optional anti-electric-shock terminal cover (part number: L4000FB) is used.

Cable Specifications and Recommended Products

Power supply and relay contact output	600V vinyl insulated wire/cable, JIS C3307, 0.9 to 2.0mm ²
Thermocouple input	Shielded compensating lead wire, JIS C1610
RTD input	Shielded wire (3-wire), UL2482 (Hitachi cable)
Other signals	Shielded wire

Recommended Terminals

Use M3.5 screw-compatible crimp-on terminals with an insulating sleeve, as shown below.

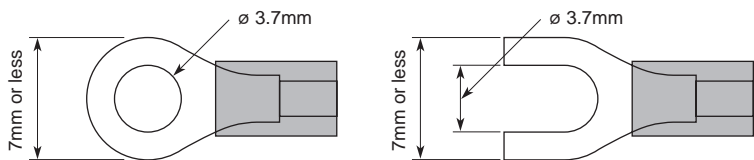

UT150L Terminal Arrangement

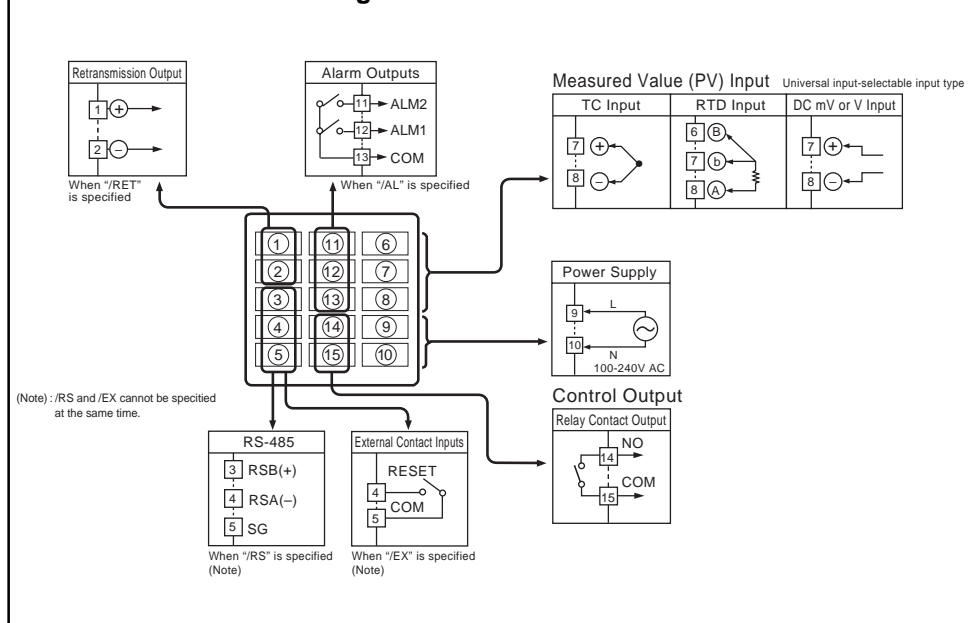

7. Key Operations (Parameter Settings)

NOTE

At power-on, the controller displays the operating display ①, but if the input range setting remains OFF, then "IN" appears. In this case, press the key to display the input range code you want to use, then press the key to register it.

- You can move between parameter setting displays using the key.
- To change the set value,
 - Change the display value with the or key (the period flashes).
 - Press the key to register the setting.
- At the operating display ① or ②, pressing the key for at least 3 seconds retrieves the operating parameter setting display.
- At the operating parameter setting display, pressing the key for at least 3 seconds transfers back to the operating display ①. Registering the key-lock parameter LOC to "1" retrieves the setup parameter setting display.
- At the setup parameter setting display, pressing the key for at least 3 seconds transfers back to the operating display ①.

Note: If you cannot change the parameter setting value, check the key-lock parameter (LOC) setting.

NOTE

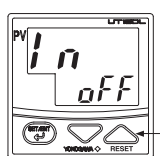

When "In" appears, press the key to display the input range code you want to use, then press the key to register it. After this operation, the controller shows the operating display ①.

6. Hardware Specifications

Measured Value (PV) Input

- Input: 1 point
- Input type: Universal; can be selected by software
- Input accuracy (at 23 ±2°C ambient temperature)
 - Thermocouple: ±2°C ±1digit
 - However,
 - ±4°C for thermocouple input -200 to -100°C
 - ±3°C for thermocouple input -100 to 0°C
 - ±5°C for type R and S (±9°C for 0 to 500°C)
 - ±9°C for type B (accuracy is not guaranteed for 0 to 400°C)
 - RTD: ±1°C ±1digit
 - Voltage (mV, V): ±0.3% ±1digit
 - Sampling period for measured value input: 500ms
 - Burnout detection: Functions for thermocouple or RTD input (burnout upscale only; cannot be switched off)
 - Input resistance: 1MΩ or greater for thermocouple or DC mV input. Approx. 1MΩ for DC V input
 - Maximum allowable signal source resistance:
 - 250Ω for thermocouple or DC mV input
 - 2kΩ for DC V input
 - Maximum allowable wiring resistance for RTD input: 10Ω/wire (The resistance values of three wires must be the same.)
 - Allowable input voltage: ±10V DC for thermocouple or DC mV input ±20V DC for DC V input
 - Noise rejection ratio: Normal mode noise: Min. 40dB (50/60Hz) Common mode noise: Min. 120dB (Min. 90dB for DC V input)
 - Error of reference junction compensation: ±1.5°C (at 15-35°C) ±2.0°C (at 0-50°C)
 - The reference junction compensation cannot be switched off.
 - Applicable standards: Thermocouple and resistance temperature detector JIS/IEC/DIN (ITS90)

Control Output

- Output: 1 point
- Output type: Relay contact output
- Relay contact output
- Contact capacity: 3A at 240V AC or 3A at 30V DC (with resistance load)
- Note: The control output relay cannot be replaced by users.

Alarm Functions

- Alarm types (Option Code /AL or /HBA)
 - Alarm types: 22 types (waiting action can be set by software): PV high limit, PV low limit, Deviation high limit, Deviation low limit, De-energized on deviation high limit, De-energized on deviation low limit, Deviation high and low limits, Deviation within high and low limits, De-energized on PV high limit, De-energized on PV low limit, Fault diagnosis output, FAIL output
 - Alarm output: 2 relay contacts
 - Relay contact capacity: 1A at 240V AC or 1A at 30V DC (with resistance load)
 - Note: The alarm output relays cannot be replaced by users.

Retransmission Output

- The retransmission output is provided only when the /RET option is specified.
- Output signal: Measured value in 4-20mA DC
- Maximum load resistance: 600Ω
- Output accuracy: ±0.3% of span (at 23 ±2°C ambient temperature)

Contact Inputs

- The contact inputs are provided only when the /EX option is specified.
- Function: Resetting "exceeded status"
- Input: 1 point
- Input type: Non-voltage contact or transistor contact input
- Contact capacity: At least 12V/10mA
- On/off judgment: On state for 1kΩ or less; off state for 20kΩ or greater

Communication Function

The communication function is provided only when the /RS option is specified. (For details, read the user's manual of the communication functions IM05C01E22-10E.)

Communication Protocol

- Personal computer link: Used for communication with a personal computer, or UT link module of the FA-M3 controller (from Yokogawa Electric Corporation).
- Ladder communication: Used for communication with a ladder communication module of the FA-M3, or a programmable controller of other manufacturers.
- MODBUS communication: Used for communication with equipment featuring the MODBUS protocol.
- Communication Interface
 - Applicable standards: Complies with EIA RS-485
 - Number of controllers that can be connected: Up to 31
 - Maximum communication distance: 1,200m
 - Communication method: Two-wire half-duplex, start-stop synchronization, non-procedural
 - Baud rate: 2400, 4800, or 9600 bps

Safety and EMC Standards

- Safety: Complies with IEC/EN61010-1 (CE), approved by C22.2 No.61010-1, approved by UL508. Certified by FM-3810 and FM-3545. Installation category: CAT. II Pollution degree: 2 (IEC/EN61010-1, C22.2 No.61010-1) Measurement category: I (CAT. I: IEC/EN61010-1) Rated measurement input voltage: 10V DC max.(across terminals), 300V AC max.(across ground) Rated transient overvoltage: 1500V (Note) Note: It is a value on the safety standard which is assumed by IEC/EN61010-1 in Measurement category I, and is not the value which guarantees an apparatus performance. Caution: This equipment has Measurement category I, therefore do not use the equipment for measurements within Measurement categories II, III and IV.

- EMC standards: Complies with EN61326, EN61000-3-2, EN61000-3-3 and EN55011 (CE). The instrument continues to operate at a measuring accuracy of within ±20% of the range during tests.

Power Supply and Isolation

Power Supply

Power supply	Voltage	Rated at 100-240VAC (±10%)
	Frequency	50 or 60Hz
Maximum power consumption		8VA max. (4W max.)
Memory		Non-volatile memory
Withstanding voltage	Between primary terminals and secondary terminals (See note 1.)	1500V AC for 1 minute
Insulation resistance	Between primary terminals and secondary terminals (See note 1.)	20MΩ or more at 500V DC

Note 1: The primary terminals are the power supply terminals and relay output terminals. The secondary terminals are the analog input and output terminals, the voltage pulse output terminals, and the contact input terminals.

Isolation

The bold lines below indicate reinforced isolation, and the broken line indicates functional isolation.

Power supply terminals (100-240V AC)	Measured value input terminals
Control output terminals (relay contacts)	2 input terminal for /EX
Alarm output terminals (2 relay contacts)	Internal circuit
	Control output terminals: Voltage pulse
	RS-485 terminals for /RS

Note: Neither the measured value input terminals nor input terminals for the /EX option are isolated from the internal circuit.

Construction, Mounting, and Wiring

- Construction: Dust-proof and drip-proof front panel conforming to IP65. For side-by-side close installation the controller loses its dust-proof and drip-proof protection.
- Casing: ABS resin and polycarbonate
- Case color: Black
- Mounting: Flush panel mounting
- Terminals: Screw terminals

Environmental Conditions

Normal Operating Conditions

- Warm-up time: At least 30 minutes
- Ambient temperature: 0-50°C (0-40°C when mounted side-by-side)
- Rate of change of temperature: 10°C/h or less
- Ambient humidity: 20-90% RH (no condensation allowed)
- Magnetic field: 400A/m or less
- Continuous vibrations of 5 to 14Hz: Amplitude of 1.2mm or less
- Continuous vibrations of 14 to 150Hz: 4.9m/s² (0.5G) or less
- Short-period vibrations: 14.7m/s² (1.5G) for 15 seconds or less
- Shock: 98m/s² (10G) for 11 milliseconds or less
- Mounting angle: Upward incline of up to 30 degrees; downward incline is not allowed.
- Altitude: 2000m or less above sea level

Maximum Effects from Operating Conditions

- Temperature effects
 - Thermocouple, DC mV and DC V input: ±2μV/°C or ±0.02% of F.S./°C, whichever is the larger
 - Resistance temperature detector: ±0.05°C/°C
 - Analog output: ±0.05% of F.S./°C
- Effect from fluctuation of power supply voltage (within rated voltage range)
 - Analog input: ±0.2μV/V or ±0.002% of F.S./V, whichever is the larger
 - Analog output: ±0.05% of F.S./V

Transportation and Storage Conditions

- Temperature: -25 to 70°C
- Humidity: 5 to 95% RH (no condensation allowed)
- Shock: Package drop height 90cm (when packed in the dedicated package)

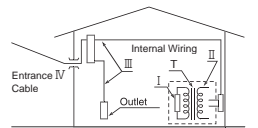

Measurement category	Description	Remarks
I CAT. I	For measurements performed on circuits not directly connected to MAINS.	
II CAT. II	For measurements performed on circuits directly connected to the low voltage installation.	Appliances, portable equipments, etc.
III CAT. III	For measurements performed in the building installation.	Distribution board, circuit breaker, etc.
IV CAT. IV	For measurements performed at the source of the low-voltage installation.	Overhead wire, cable systems, etc.

UT150L Measured Input Range Codes List

Input type	Range (°C)	Range code (C)	Range (°F)	Range code (F)
Thermocouple	Unspecified	OFF		
	-270 to 1370°C	1	-300 to 2500°F	31
	0.0 to 600.0°C	2	32.0 to 999.9°F	32
	0.0 to 400.0°C	3	32.0 to 750.0°F	33
	-199.9 to 200.0°C	4	-300 to 400°F	34
	-199.9 to 999.9°C	5	-300 to 2100°F	35
	-300 to 400.0°C	6	-300 to 750°F	36
	-199.9 to 999.9°C	7	-300 to 1800°F	37
	0 to 1700°C	8	32 to 3100°F	38
	0 to 1700°C	9	32 to 3100°F	39
	0 to 1800°C	10	32 to 3200°F	40
	-200 to 1300°C	11	-300 to 2400°F	41
	-199.9 to 900.0°C	12	-300 to 1600°F	42
-199.9 to 400.0°C	13	-300 to 750°F	43	
Platinum 2	0 to 1300°C	14	32 to 2300°F	44
	-199.9 to 850.0°C	15	-199.9 to 999.9°F	45
	0.0 to 400.0°C	16	32.0 to 750.0°F	46
	-199.9 to 200.0°C	17	-300 to 400°F	47
	-19.9 to 99.9°C	18	No range	—
	-199.9 to 500.0°C	19	-199.9 to 999.9°F	48
DC voltage	0 to 100mV	20		
	0 to 5V	21		
	1 to 5V	22		
	0 to 10V	23		

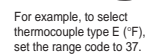

For example, to select thermocouple type E (°F), set the range code to 37.

CAUTION

To prevent electric shock, the controller should be mounted on the panel so that you do not accidentally touch the terminals when power is being applied.

NOTE

The controller is shipped with the parameters set at the factory-set defaults. Check the default values against the "Parameter List" in the following page, and change the parameter settings that need to be changed.

The following section (on Page 3) explains how to set and register parameter values.

The procedure for changing SP (target setpoint) can be found on "Changing Setpoint (SP)". You can set the other parameters in the same way.

There are no setup displays for parameters specific to functions, such as the optional alarm output functions, if they were not selected at ordering.

The setting of some parameters (such as the Alarm 1 type parameter AL1) determines whether the other parameters (Alarm 1 setpoint: A1) are displayed or not.

The flowchart will help you understand how this works.

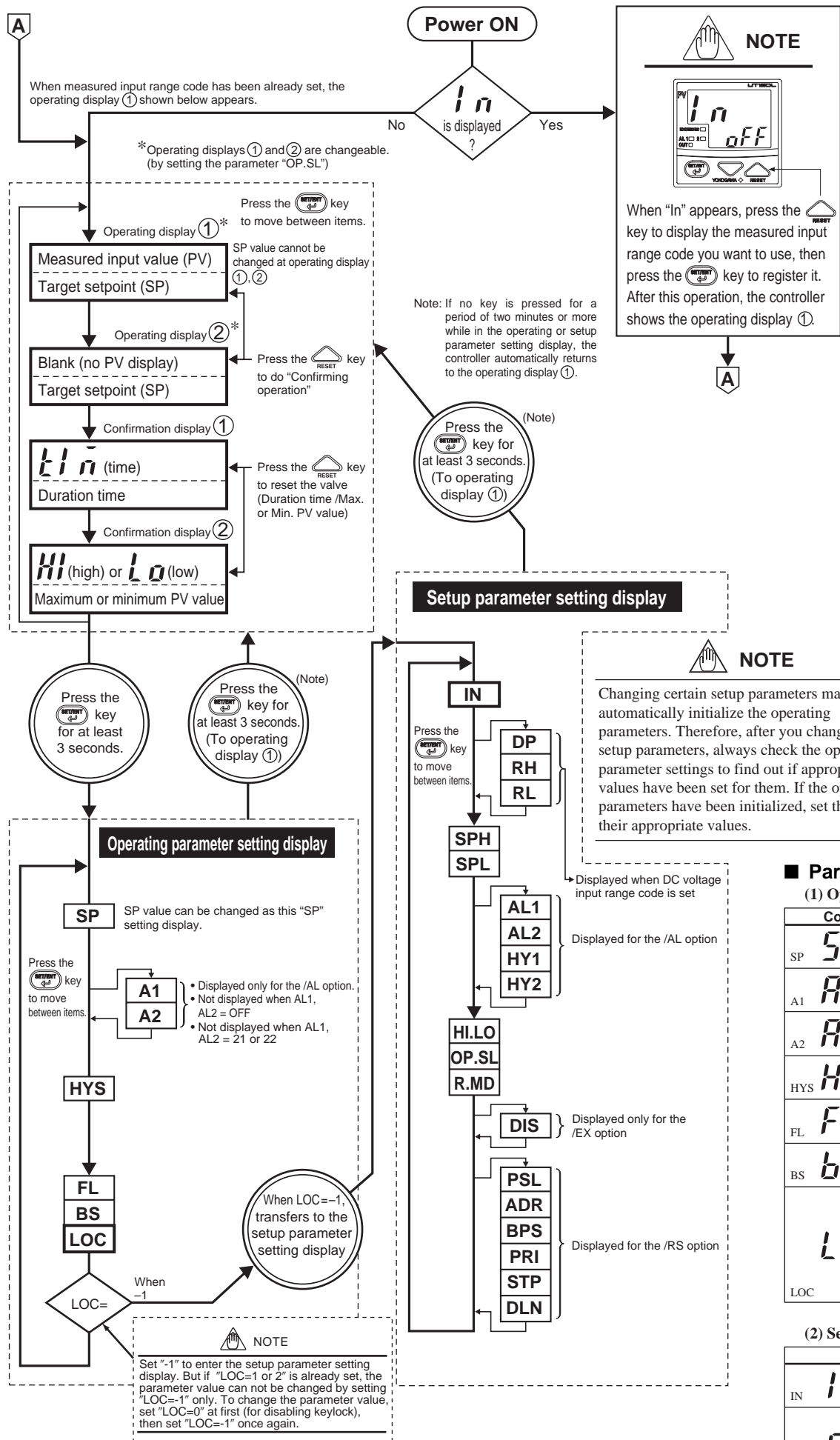

Changing Setpoint (SP)

Step 1: Confirm that the controller shows the operating display ① or ② during normal operation.

Step 2: To enter the operating parameter setting display, press the key for at least 3 seconds. The display for the setpoint (SP) appears.

Step 3: Press the key or key to change the current SP value to the required value. In this example, SP is changed to 200°C. The period flashes while the value is being changed.

Step 4: Press the key once to register the setting. SP is now changed. Another press of the key calls up the Alarm-1 setpoint display. To return to the operating display ①, press the key for at least 3 seconds.

Parameter Lists

Numbers in () are the parameter setpoints that apply when the communication function is used. Ex. OFF(0), ON(1)

(1) Operating Parameters: Parameters changed rather frequently during operation.

Code	Name	Setting range and unit	Default	User setting
SP	Setpoint for limit alarm	Minimum value (SPL) to maximum value (SPH). Unit: °C/°F		
A1	Alarm 1 setpoint	■ PV alarm Unit: °C/°F Setting range: minimum value to maximum value of measured input range (scale)	Max. value of measured input range (scale) (PV alarm)	
A2	Alarm 2 setpoint	■ Deviation alarm Unit: °C/°F Setting range: -100 to 100% of the measured input range (scale) span	Min. value of measured input range (scale) (PV alarm)	
HYS	Relay hysteresis for control output	0°C/°F to the temperature that corresponds to 100% of the measured input range (scale) span	0.5% of measured input range (scale) span	
FL	PV input filter	OFF(0), 1 to 120 seconds	OFF(0)	
BS	PV input bias	-100 to 100% of measured input range (scale) span	0% of measured input range (scale) span	
LOC	Key lock	0: No key lock 1: Prevents operations from being changed except for the changing of SP 2: Prevents all parameter changing operations -1: Set "-1" to enter the setup parameter setting display. But if "LOC=1 or 2" is already set, the parameter value can not be changed by setting "LOC=-1" only. To change the parameter value, set "LOC=0" at first (for disabling keylock), then set "LOC=-1" once again.	0	

(2) Setup Parameters: Parameters rarely changed in normal use after once having been set.

Code	Name	Setting range and unit	Default	User setting
IN	Measured input type	1 to 23, and 31 to 48 (See input range code list on Page 2.) OFF(0): No input (If no input type is specified at the time of ordering, you must set the input type.)	OFF(0), or the input range code specified with order	
DP	Decimal point position of measured input	0: No decimal place (nnnn) (Displayed at voltage input) 1: One decimal place (nn.n) 2: Two decimal places (nn.nn) 3: Three decimal places (n.nnn)	1	
RH	Maximum value of measured input range (scale)	(RL + 1) to 9999 (Displayed at voltage input) Unit: %	100.0	
RL	Minimum value of measured input range (scale)	-1999 to (RH - 1) (Displayed at voltage input) Unit: %	0.0	
SPH	Maximum value of setpoint range	(SPL+1°C) to the maximum value of the measured input range (scale); Unit: °C/°F	Maximum value of measured input range (scale)	
SPL	Minimum value of setpoint range	Minimum value of measured input range (scale) to (SPH - 1°C) Unit: °C/°F	Minimum value of measured input range (scale)	
AL1	Alarm 1 type	OFF(0) or a value from 1 to 22 (see the table of alarm function list)	1 (PV high limit alarm)	
AL2	Alarm 2 type	OFF(0) or a value from 1 to 22 (see the table of alarm function list)	2 (PV low limit alarm)	
HY1	Alarm 1 hysteresis	0 to 100% of measured input range (scale) span Unit: °C/°F	0.5% of measured input range (scale) span	
HY2	Alarm 2 hysteresis	0 to 100% of measured input range (scale) span Unit: °C/°F	0.5% of measured input range (scale) span	
HI.LO	Limit control type	HI(0): High limit LO(1): Low limit	HI(0)	
OP.SL	Operating display selection	0: PV and SP 1: Only SP (No PV display)	0	
R.MD	Restart mode	0: Limit output is ON at power on in any cases. 1: Limit output is OFF at power ON when PV doesn't exceed SP.	0	
DIS	The way of confirming operation	KEY(0): By key operation DI(1): By digital input	KEY(0)	
PSL	Protocol selection	0: PC-link communication 1: PC-link communication with sum check 2: Ladder communication 3: MODBUS in ASCII mode 4: MODBUS in RTU mode	0	
ADR	Controller address	1 to 99 However, the number of controllers that can be connected per host device is 31 at the maximum.	1	
BPS	Baud rate	2.4(0): 2400 bps 4.8(1): 4800 bps 9.6(2): 9600 bps	9.6(2)	
PRI	Parity	NON(0): Disabled EVN(1): Even parity ODD(2): Odd parity	EVN(1)	
STP	Stop bit	1 or 2 bits	1 bit	
DLN	Data length	7 or 8 bits • 8 bits when ladder, MODBUS (RTU) • 7 bits when MODBUS (ASCII)	8 bits	

Alarm Function List

Alarm type	Action	Alarm type code	Alarm type	Action	Alarm type code
No alarm		OFF			
PV high limit	Hysteresis Opn (off) → Alarm setting → Cls (on)	1 11 (See note.)	De-energized on deviation low limit	Hysteresis Opn (on) → Alarm setting → Cls (off)	6 16 (See note.)
PV low limit	Hysteresis Cls (on) → Alarm setting → Opn (off)	2 12 (See note.)	Deviation high and low limits	Hysteresis Cls (on) → Opn (off) → Cls (on)	7 17 (See note.)
Deviation high limit	Hysteresis Opn (off) → Alarm setting → Cls (on)	3 13 (See note.)	Deviation within high and low limits	Hysteresis Opn (off) → Cls (on) → Opn (off)	8 18 (See note.)
Deviation low limit	Hysteresis Cls (on) → Alarm setting → Opn (off)	4 14 (See note.)	De-energized on PV high limit	Hysteresis Cls (off) → Alarm setting → Opn (on)	9 19 (See note.)
De-energized on deviation high limit	Hysteresis Cls (off) → Alarm setting → Opn (on)	5 15 (See note.)	De-energized on PV low limit	Hysteresis Opn (on) → Alarm setting → Cls (off)	10 20 (See note.)
Fault diagnosis output	The contact is closed at input burnout.	21	FAIL output	The output contact is opened in the following events: • Program error • A/D converter error • ROM error • RAM error • power failure	22

Note: The alarms numbered 1 to 10 have no waiting action, while alarms 11 to 20 have a waiting action. The waiting action turns off the PV and deviation alarms that occur from the start of the control operation until a stable state is reached.

Waiting action

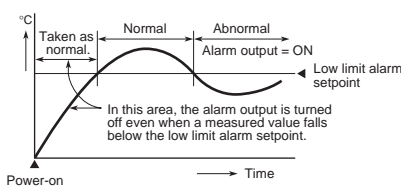

Description of Parameters

This section describes the parameter functions specific to the UT150L limit controller. (The functions described in other sections of this manual and the general functions are not discussed.)

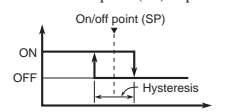
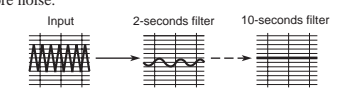
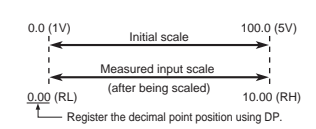
Parameter	Function
Relay hysteresis for control output HYS	For control, you can set a hysteresis around the on/off point (SP) to prevent chattering. 
PV input filter FL	This function should be used when the PV display value may fluctuate greatly, for example, when the measured input signal contains noise. The filter is of the first-order lag type, and FL sets the time constant. If a larger time constant is set, the filter can remove more noise. 
PV input bias BS	This function adds a bias value to the measured input value, and the result is used for display and control computation. $\text{PV value inside the controller} = \text{measured input value} + \text{PV input bias}$ This function is useful for carrying out fine adjustment when the PV value is within the required accuracy but it differs from the value obtained by other equipment.
Decimal point position of measured input DP	For DC voltage input, the input signal can be scaled for the particular engineering unit. For example, if you set the input type (IN) at range code 22, the initial range is 0.0 to 100.0. a. Using DP, set the decimal point position fit for the engineering unit you want to use. (In the example below, the 2 digits to the right of the decimal point) b. Next, register the scale values of the measured input scale using RH and RL. (In the example below, RH=10.00 and RL=0.00) 
Maximum/minimum value of measured input range (scale) RH, RL	Using the SPH and SPL parameters, you can limit the setting range of the target setpoint (SP) within the measured input range (scale). This function prevents SP from being mistakenly set at too large or too small a value (beyond the setting range). SPH, SPL

8. Limit Control Function

Limit Control

When a measured value (PV) exceeds a setpoint (SP), "EXCEEDED" lamp lights, and "OUT" lamp turns ON (A). The limit output relay is de-energized then. "EXCEEDED" lamp turns off when PV goes into normal condition, while the output (OUT) display lamp stays on as it is (B). The output (OUT) display lamp turns off when a confirming operation is done by an operator (C). The way to confirm is pressing the "RESET" key (or by an external contact, according to the setting of setup parameter DIS). The confirming operation is not accepted during PV exceeds SP (D) (during EXCEEDED lamp lights*). State of output relay is de-energized whenever "OUT" lamp is on.

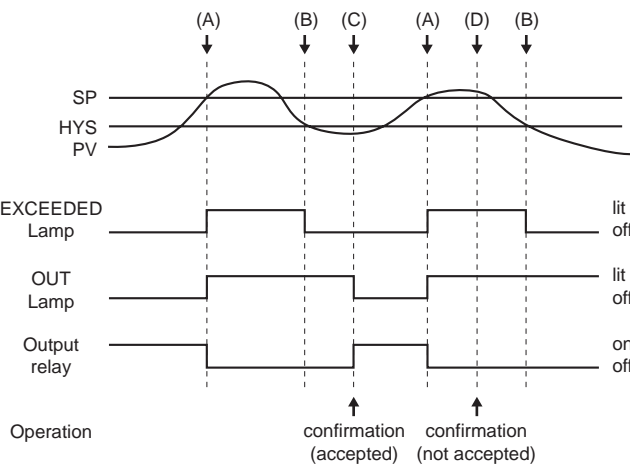

* Check the "HYS" value if the EXCEEDED lamp is not turn off when PV is lower than SP.

NOTE

The confirming operation cannot be done by communication (RS-485).

Confirming Operation

Do the confirming operation when you start limit control. This operation must be necessary every time when the controller is powered on. By the confirming operation, state of output relay is energized and the output (OUT) display lamp turns off, if the PV does not exceed SP.

Step 1: Confirm that the controller shows the operating display ① and the output (OUT) display lamp lights.

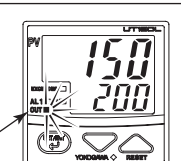

Step 2: Press the "RESET" key for at least 1 second to turn off the output (OUT) display lamp. The confirming operation is now finished.

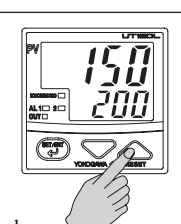

Note 1: The output (OUT) display lamp does not turn off during the EXCEEDED lamp lights.
Note 2: Check the "HYS" value if the EXCEEDED lamp is not turn off when PV is lower than SP.

Power On Status

The state of output relay at power-on can be set by a setup parameter restart mode "R.MD".

(1) When "R.MD" is set to 0.

The output relay is always de-energized (opened) at power-on, even if PV does not exceed SP (A). The output (OUT) display lamp is lit. After the confirming operation, state of output relay is energized (closed) and the output (OUT) display lamp turns off if the PV does not exceed SP (B).

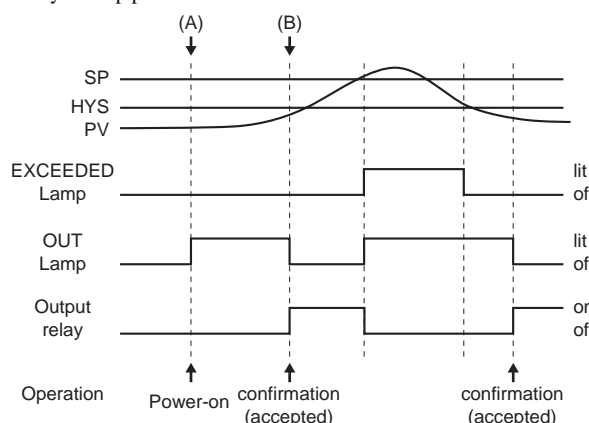

Fig.1 Power-on status of high limit control when R.MD = 0

Duration Time (Refer to the confirmation display ① in the flowchart on page 3)

The time while PV exceeds SP is counted and stored in the memory. It is displayed in the "TIME" in the confirmation display ①.

Display time range: 00.00 to 99.59

How to RESET

- Push the "RESET" key for about one second to reset the duration time in the confirmation display ① where "TIME" is displayed. When the count is reset, "0.00" is displayed until PV exceeds SP again.
- The time count is reset when power is turned on.
- If PV exceeds SP while the old time count data is retained in the memory, the old data should be automatically reset, and the new time counting starts from "0.0".
- It is impossible to reset the time count while PV exceeds SP by any operation.
- Duration time cannot be reset by an external contact or communication (RS-485).

Maximum/Minimum Value

The maximum value or minimum value of PV is stored in the memory and displayed in the "HI" or "LO" display in the confirmation display ②.

When the control type is specified as high limit control, the maximum value is displayed in the "HI" display, and the control type is specified as low limit control, the minimum value is displayed in the "LO" display. When the PV exceeds SP and then return to the normal status, Maximum/Minimum value is retained as it is, but when PV exceeds SP again, it is automatically reset and start taking new value for its maximum/minimum value.

How to RESET

- Push the "RESET" key for about one second to reset the maximum/minimum value in the confirmation display ② where "HI" or "LO" is displayed. The value is reset, and the value immediately after the confirmation should be recognized as a maximum or minimum value.
- When the power is turned-on, the memory should be reset and the first PV should be recognized as maximum.
- Maximum/minimum value cannot be reset by an external contact or communication (RS-485).
- It is impossible to reset the maximum/minimum value while PV exceeds SP by any operation.

9. Troubleshooting

In the event of an abnormality, perform the following checks as outlined by the flowchart.

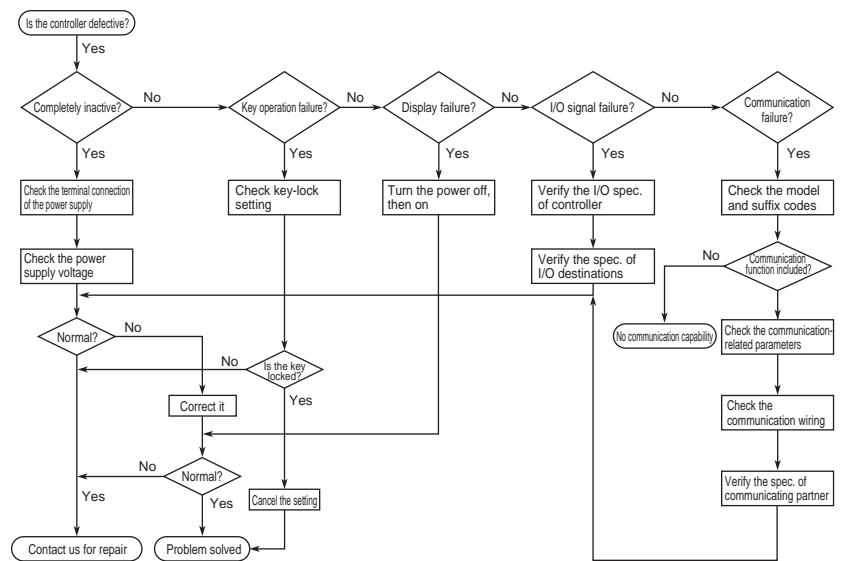

Error Display during Operation

(1) If the controller displays one of the following, carry out the appropriate remedy for the particular error.

Display	Error content	Remedy
P.Er P.Er	The parameter is abnormal	Check the settings of all the parameters and set them at their proper values.
b.o B.o	Input burnout	Check the sensor wiring and correct it.
000 OOO	PV over-scale (PV exceeds its effective range.)	Check the input type and range settings and correct them.
UUU UUU	PV under-scale (PV falls below its effective range.)	
Flashing period on PV display	Communication failure (for /RS option only)	Press any key to stop the flashing.

(2) The controller needs to be repaired if any of the indications in the table below appear.

In these cases, do not try to repair the controller yourself. Order a new controller or contact us for repair.

Display	Error content	Display	Error content
Unknown (at power-on)	CPU failure	Flashing "Err" (at power-on)	RAM or ROM failure
All extinguished (at power-on)	Power source failure	Flashing "Err" (during operation)	A/D converter failure, RJC failure, or EEPROM failure
"Err" (at power-on)	Calibration abnormal		

When Power Failure Occurred during Operation

- Momentary power failures of less than 20ms have no effect on the controller operation (i.e., normal operation continues).
- For power failures longer than 20ms, however the status will be as follows.
(The controller action at power recovery is the same as at power-on.)
 - Alarm action: Continues (but alarms with a waiting action enter the waiting state once)
 - Setting parameters: Maintained

(2) When "R.MD" is set to 1.

The state of output relay is energized (closed) and the output (OUT) display lamp turns off if the PV does not exceed SP at power-on.

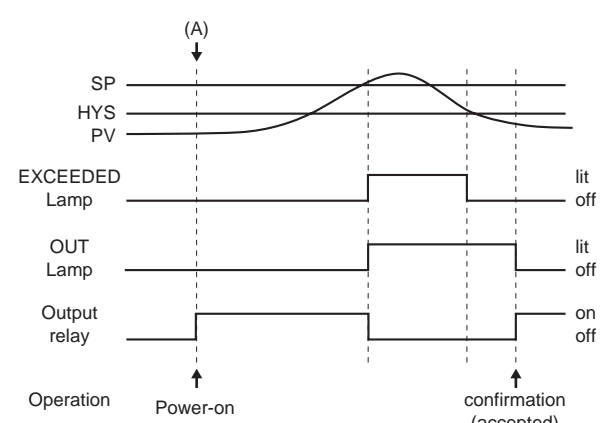

Fig.2 Power-on status of high limit control when R.MD = 1